



SuperBus 2000 RF Transceiver Module Installation Instructions

466-2184D
May 2005

Description

The SuperBus 2000 RF Transceiver Module expands the RF reception range of compatible GE control panels when located in the vicinity of sensors on the fringe of panel reception. The transceiver works with all GE Security wireless sensors and touchpads. It receives signals from wireless sensor and touchpads, then sends the data to the panel via the SuperBus 2000 digital data bus.

A tamper switch activates an alarm if the cover is removed while the system is armed. Power for the module is provided by the panel.

Installation

The module comes as a kit that is assembled in the field. Installation consists of the following tasks:

- Mounting
- Wiring
- Power up

Installation guidelines

Observe the following guidelines when installing the transceiver module:

- Allow at least 9 inches (22.9 cm) of clearance above the enclosure for the antennas.
- Up to 4 SuperBus 2000 RF Transceiver Modules can be connected to Concord 4/Concord Express V4 panels (see model numbers in *Specifications* on page 3). Use the wire length guidelines in the following table.

Wire gauge (shielded or unshielded)	Maximum wire length between module and panel
22 AWG (0.65 mm)	1,000 feet (305 m)
18 AWG (1.02 mm)	2,500 feet (762 m)

- The module must be installed in its own plastic enclosure. It cannot be installed inside the panel's enclosure.
- Avoid mounting locations that are likely to expose the module to moisture.
- Avoid areas with excessive metal or electrical wiring including furnace and utility rooms. If unavoidable, mount on or near metal with the antenna extending above the metallic surfaces as shown in *Figure 1*.

Figure 1. Mounting on or near metal

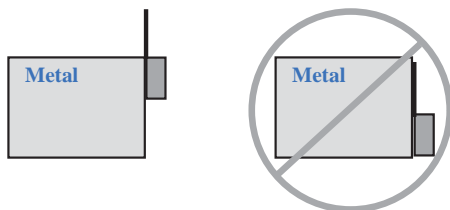

Tools and supplies

To complete the installation, you will need the following tools and supplies:

- Screwdrivers
- Drill with bits
- Mounting screws and anchors (included)
- 4-conductor, 22-gauge (0.65 mm) or larger, stranded wire

Mounting

The module can be mounted on any interior wall (protected from the elements). To mount the module, do the following:

1. Remove the module back plate from the packaging.
2. Hold the base against the mounting surface and mark the two mounting holes and the wire access hole as shown in *Figure 2*. Remember to leave at least 9 inches (22.9 cm) above the back plate for the antennas.

Note: The wire access hole is molded into the plastic so that you can access the wire, yet keep it hidden behind the back plate.

Figure 2. Back plate

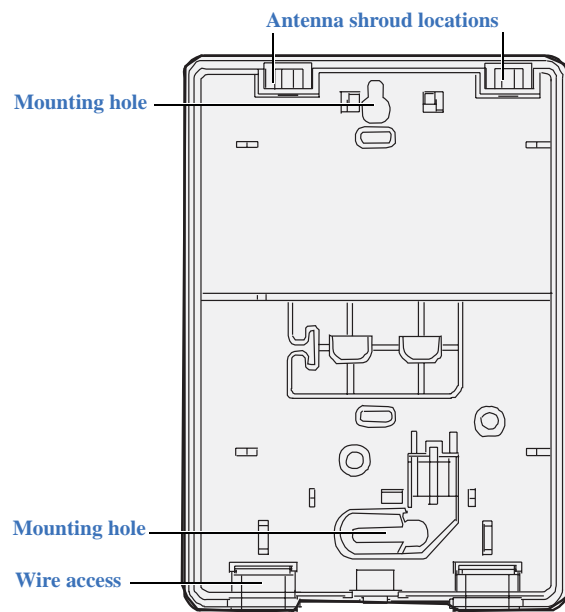

3. Drill holes and insert the appropriate anchors (included).
4. Run a 4-conductor, 22- or 18-gauge (0.65 or 1.02 mm) stranded wire cable from the module wire access hole location (*Figure 2*) to the panel.

Note: For model 600-1025-01-43, the cable length must be less than 3 m (9.8 ft.) for CE compliance.

5. Secure the back plate to the wall with the pan head screws provided.
6. To assemble the antenna shrouds, attach the proper number of sections together, then attach the top cap.
7. Install each antenna shroud on top of the back plate (*Figure 2*).
8. Remove the transceiver circuit board from the anti-static bag.



CAUTION

You must be free of static electricity before handling circuit boards. Wear a grounding strap or touch a bare metal surface to discharge static electricity.

9. To install the circuit board onto the back plate (*Figure 3*), insert the antennas into the antenna shrouds, then gently slide the top of the circuit board under the two top latches,

and snap the circuit board in at the bottom latch to secure it in place.

Figure 3. Circuit board and back plate.

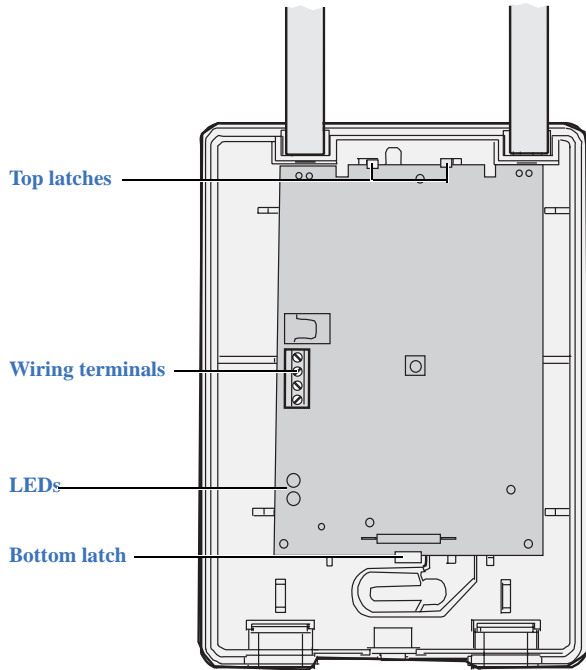

Wiring

To wire the transceiver module to Concord 4 and Concord Express V4 panels, do the following:

1. Unplug the panel power transformer and disconnect the backup battery.
2. Wire the module to the panel power and bus terminals as shown in Figure 4.

Figure 4. Module to panel wiring connections

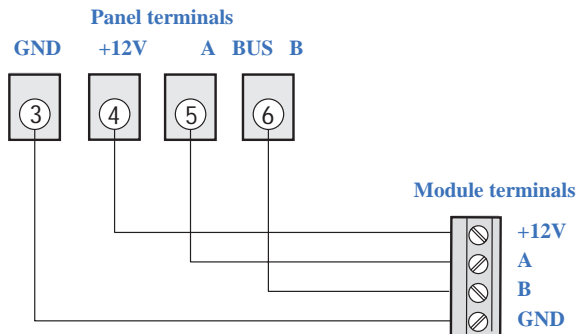

Power up

To power up the system and verify bus communication, do the following:

1. Verify that all wiring at the panel, touchpad, and transceiver is correct.
2. Connect the panel backup battery and plug in the panel AC power transformer. The panel automatically learns the transceiver bus ID number.

- The red LED should turn on to indicate bus communication with the panel.
- The green LED should turn on to indicate that power is present and it should flicker off and on each time a wireless sensor RF packet is received.

Note: If the green LED is not on, unplug the panel AC power transformer, disconnect the backup battery, and proceed to Troubleshooting.

Troubleshooting

Problem	Action
Green and red LEDs are off	1. Check that the panel is powering up. 2. Check/correct module to panel wiring.
Green LED is on, red LED is off	Check/correct bus (A and B) wiring connections of module and panel.
System is not responding to wireless sensor signals	1. Check that the green LED flickers when a wireless sensor is tripped. 2. Check that the transceiver is learned into the panel memory.

Trademark/disclaimer

SuperBus is a registered trademark of GE Security, Concord is a trademark of GE Security. All other trademarks are the property of their owners.

FCC compliance

This device complies with FCC Rules Part 15. Operation is subject to the following two conditions:

1. This device may not cause harmful interference.
2. This device must accept any interference that may be received, including interference that may cause undesired operation.

Changes or modifications not expressly approved by GE Security can void the user's authority to operate the equipment.

Specifications

Models	600-1025-01-95R and 600-1025-01-43
Frequency	
600-1025-01-95R	319.5 MHz
600-1025-01-43	433.92 MHz
Panel compatibility	UL approved Concord 4, Concord 4 Commercial, and Concord Express V4, model numbers 600-1021-95R, 600-1040, and 600-1022-95R CE European Concord compatible panels
Sensor compatibility	
600-1025-01-95R	All 319.5 MHz sensors
600-1025-01-43	All 433 MHz sensors
Current required (without daughter board)	
Typical	45mA
Maximum	100mA
Voltage	8 to 15 VDC
Wireless range	1,000 feet (305 m)
Listings	
600-1025-01-95R	UL (985, 1023, 1610), FCC ID (B4Z-875-TCVR), CUL (C1023-1974, S545-M89), IC: 867-875CVR
600-1025-01-43	CE
Operating temperature	32 to 120°F (0 to 49°C)
Storage temperature	-30 to 140°F (-34 to 60°C)
Maximum relative humidity	85% noncondensing
Dimensions	3.2 x 4.6 x 0.6 inches (8.1 x 11.7 x 1.5 cm)
Features	Antenna tamper, jam detect, wall tamper, cover tamper
Enclosure	600-1029

CE declaration of conformity



Manufacturer's name:	GE Security
Manufacturer's address:	1275 Red Fox Road Arden Hills, MN 55112 USA
EU representative:	GE Security B.V. Kelvinstraat 7 6003 DH Weert The Netherlands
Product identification:	Product: 433 MHz SB2000 Transceiver Model number: 600-1025-01-43 Brand: GE Security
R&TTE directive:	
EMC:	TUV 0123 / GE Security Test report reference: CEQP-600-1025-01-43 Applied standards: EN50130-4 (1995) +A1 (1998)
Safety:	GE Security Test report reference: CEQP-600-1025-01-43 Applied standards: EN60950-1:2001
Radio:	TUV 0123 Test report reference: CEQP 600-1025-01-43 Applied standards: EN300220-3 v1.1.1 (09-2000)
Equipment class identifier:	None (class 1 product) (RF products falling under the scope of R&TTE)

Means of conformity

We declare under our sole responsibility that this product is in conformity with Directive 93/68/EEC (Marking) and/or complies to the essential requirements and all other relevant provisions of the 1999/5/EC (R&TTE) based on test results using (non) harmonized standards in accordance with the Directives mentioned.

Copyright © 2005, GE Security Inc. All rights reserved.

Technical support

Toll-free: 888.437.3287 (US including Alaska and Hawaii; Puerto Rico; Canada)
Outside the toll-free area: Contact your local dealer.